

NOTES:

1. TAPPING SADDLES ARE NOT ALLOWED FOR MAIN-ON-MAIN TAPS.
2. USE MUELLER OR AMERICAN DARLING DUCTILE IRON OR 316 STAINLESS STEEL TAPPING SLEEVES FOR TAP SIZES 4" - 24".
3. USE 316 STAINLESS STEEL TAPPING SLEEVES BY DRESSER OR CASCADE FOR TAPS ON MAINS 30" AND GREATER.
4. BOLTS AND NUTS FOR ALL TAPPING SLEEVES SHALL BE 316 SS.
5. USE THRUST BLOCKING ONLY FOR WET TAPS UNLESS OTHERWISE APPROVED BY CPW.
6. DEPTH FROM GROUND SURFACE TO TOP OF BLOCKING SHALL BE GREATER THAN HEIGHT OF BLOCKING.
7. THE END OF THE TAPPING SLEEVE SHALL BE NO CLOSER THAN 4 FEET TO A JOINT.

| TAP SIZE | DIMENSIONS IN FEET | | |
|----------|--------------------|-----|-----|
| | W | H | D |
| 4" & 6" | 2.0 | 1.4 | 1.0 |
| 8" | 3.5 | 2.0 | 1.4 |
| 10" | 4.0 | 2.5 | 1.8 |
| 12" | 5.0 | 3.0 | 2.5 |

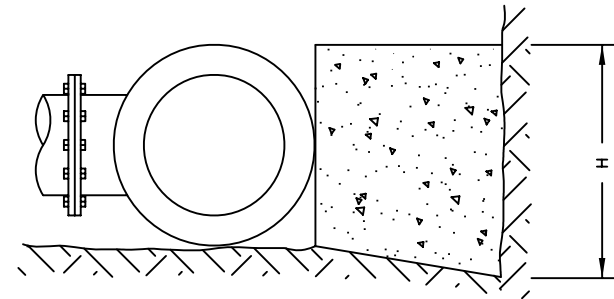
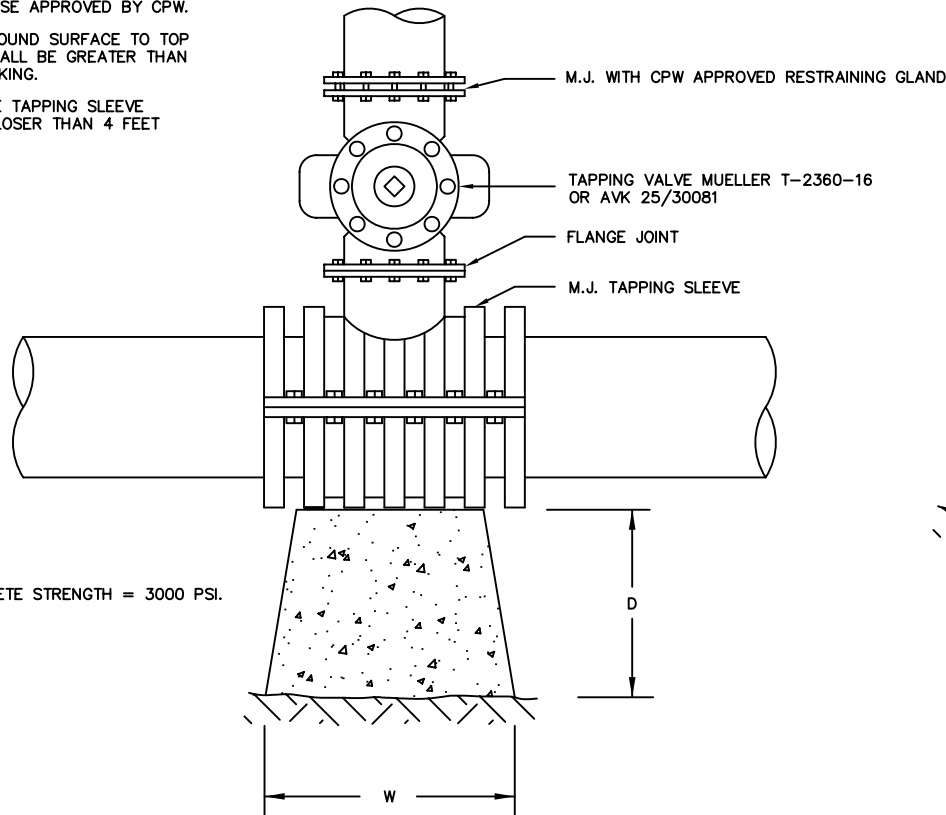

TYPICAL TAPPING SLEEVE

CHARLESTON COMMISSIONERS
OF PUBLIC WORKS

TYPICAL TAPPING SLEEVE

APPROVED BY:

CPW

DATE:

MAR 2000

DRAWING NO.

SCALE:

NTS

REVISED:

NOV 2007

8